



GSM 2G/4G GATE OPENER 240V



MODEL NUMBER GSM-4G-GATE V14



Product Information

The GSM 2G/4G Gate Opener incorporates a professional industrial grade GSM engine that receives calls at its sim number, as any ordinary GSM phone. The system operates in the GSM module quad-band 850/900/1800/1900/2100mhz and has 2G and 4G capabilities when using a 2G or 4G simcard.

Just to give an example, if your SIM has a phone number 9228 9810555, this is the number you call to open the gates. The system has a memory where you will store the numbers of people enabled to open the gate (up to 200). When the Gate Opener receives a call, it will check the calling number. If the number is a stored number it will reject the call and open the gate. Therefore, avoiding any call charges being incurred.

The advantages of this over other systems is that you do not have to leave your car to open the gates, avoiding weather and safety issues. Furthermore, you do not need to carry around a separate remote device or indeed replace it if it were to get lost!

Specification

- Simply Dial the Simcard Number to Open the Gate. It will Reject the Call Avoiding Charges Being Incurred.
- Phone List for Added Security (up to 200)
- Text for Signal Strength
- Text for Fast/Slow Relay Pulse
- Text to Keep the Gate Open (relay 1).
- Text to Open the Gate for Pedestrian Access (relay 2).
- Micro 2G 3G 4G simcard
- Antenna Supplied
- Sim Active Function
- Dimensions - L150 x W90 x H45mm
- Dimensions PCB Only - L125 x W67mm
- Operating Temperature -10 to +40c
- INPUT - 240VAC (12/24VDC / 115VAC is available)
- Output Relays are 10Amp N/O or N/C Volt Free
- Quadband Frequency - 850/900/1800/1900/2100mhz
- 4G Bands : B1 -B5, B7 - B8, B12 - B14, B18 - B20, B25 , B26, B28 , B66, B71
- No Need to Keep Replacing Remote Keyfobs When They are Lost

Instructions

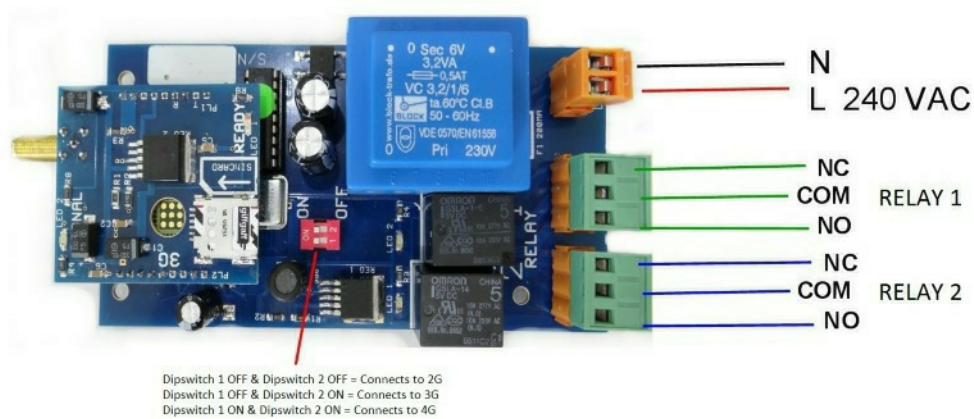

IMPORTANT - PLEASE READ

Please ensure that you disconnect the power when you fit the simcard. Then slide the simcard into the holder ensuring the clipped corner of the simcard lines up with the clipped corner of the simcard holder.
As shown in the picture above.

Powering the 2G/4G Gate Opener

Connect 240 volts to the input connector as per figure 1. Once power has been applied the blue network LED light will flash once every second. Once a signal has been found the green ready LED will come on and stay on indicating the unit is ready to use.

Signal Strength

To help ensure that you place the unit in a suitable position you can text the unit:

#SIGNAL#

The dialler will perform a test on the signal strength. You will then receive a signal strength score of between 0 up to 30. We strongly recommend placing the unit where you can receive a signal strength score of at least 10. Anything less than that will render the unit unreliable.

2G or 4G

The GSM Gate Opener can work on both 2G and 4G networks depending on which model you have. You can choose which network the unit will use at the start up using the following dipswitch settings

Dipswitch 1 OFF = Connects to 2G

Dipswitch 1 ON = Connects to 4G

We strongly recommend checking the signal strength on 2G and 4G and using which has the highest signal strength score. The signal strength should be at least a score of 10 for reliability.

Note we no longer supply 3G models as 3G will be stopped in Europe late part of 2022

How to Programme the 2G/4G GSM Gate Opener

Once the unit has a **green** LED light it is ready to use. The unit has a caller ID function so only authorised numbers you store can activate the unit. If caller ID is left OFF anyone phoning the units number can operate the relays.

PLEASE NOTE - The **hashtag** and **equals** symbols have been colour coded to make it easier.

To turn caller ID on send a text message

#ID=ON#

To turn caller ID off send a text message

#ID=OFF#

NOTE - If you do not require authorised users please skip to the next page.

Programming Caller ID

To programme a number to the caller ID (WHL), send this text message code:

#WHL=NUMBER#

To delete the number send the text message code

#DEL=NUMBER#

Example **#WHL=07123456789#** Stores your mobile number (max 200 users).
 #DEL=07123456789# Deletes your mobile number

If the code is accepted the unit will reply "WHL number stored" or "WHL number deleted"

IMPORTANT - PLEASE READ

You can only send one number at a time. Please send the message and wait for the text acknowledgement before you attempt to add another number.

Please ensure that you have credit on the simcard to receive the text acknowledgement. It may take some time to receive a text acknowledgement depending on how busy your telephone provider is at the time.

Reset Function

For a quick reset and to clear all numbers there is a built in reset function that can be triggered by sending the text

#RESET#

The unit will remove all WHL numbers stored and return to factory settings

How to Use the 2G/4G Gate Opener

Using your mobile phone or landline, dial the simcard number. You will hear 1 ring tone. The unit will automatically hang up. This will prevent any call charges being incurred. The relay will then pulse for a period of time. This is the unit sending the signal to your gate control board to open the gate.

PLEASE NOTE - Calling in using the 4G mode can currently be inconsistent due to several factors such as, signal strength, voice over LTE (4G calling) being available on simcards and phones etc. If you experience unreliability on 4G please boot the unit up using 2G or 3G depending on which has the better signal strength.

Relay Pulse Time

The unit has an adjustable pulse time for the phone call activation. The unit will either pulse for 1 second or 3 seconds as some gate controls need a very quick pulse and others a slower pulse.

To change the pulse time you will need to send the text message

#SLOW# - Sets the relay pulse time to 3 seconds
#FAST# - Sets the relay pulse time to 1 second

The default setting is slow

Texting the Gate to Open

If you need to keep the gate permanently open or open for a longer period of time, you can send the text:

#OPEN#

To close the gate simply call the simcard number. This will cancel the relay and close the gate.

IMPORTANT - PLEASE READ

Some gate systems do not have the facility to allow the gate to stay open. Please refer to your gate control system manual for further information

Pedestrian Access

Relay 2 controls the pedestrian gate. You will need to text the unit:

#PEDESTRIAN#

This will pulse relay 2 on for 3 ½ seconds. This should be sufficient time to open the gate to allow for pedestrian access.

SIM Active Function

The unit has a sim active function which monitors the activity on the simcard. If it has been inactive for 6 weeks it will send a phone call to a pre-recorded number. This will eliminate the problem of sim's getting shut down if they are unused for 3 months.

ELECTRICAL CONNECTION TABLE

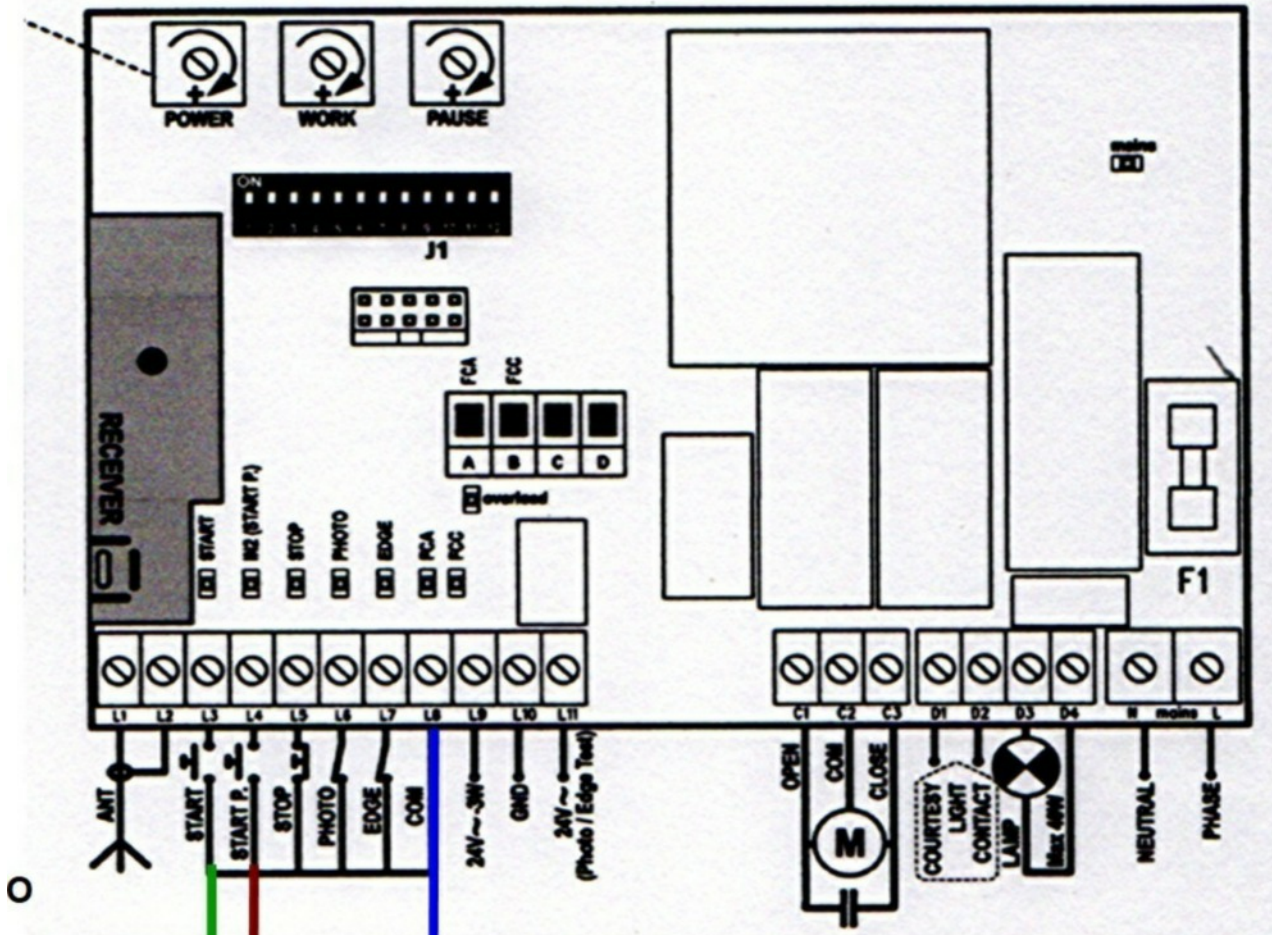

connect to NO & COM

Mains in

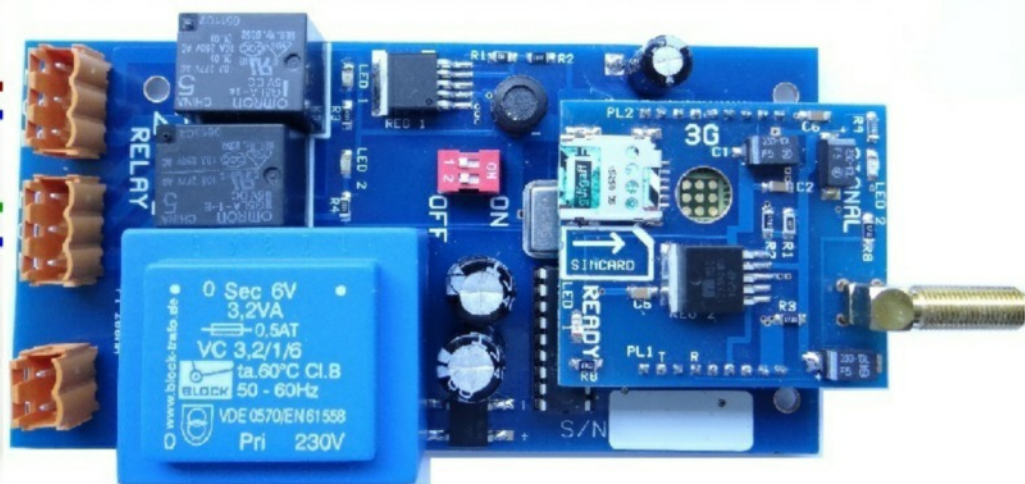

SEND TEXT	OPERATION	ACKNOWLEDGMENT
#PEDESTRIAN#	Pulses Relay 2	Gate Opens
#OPEN#	Locks Relay 1 ON	
#SLOW#	Sets Pulse Relay Time to 3 Seconds	
#FAST#	Sets Pulse Relay Time to 1 Second	
#WHL=NUMBER#	Stores Number to White List	Number Stored
#DEL=DELETE#	Deletes Number from White List	Number Deleted
#RESET#	Resets to Factory Settings	
#ID=ON#	Sets Caller ID to ON	ID = ON
#ID=OFF#	Sets Caller ID to OFF	ID = OFF
#SIGNAL#	Gives Signal Strength Test	Score 1-30

For more technical support please browse the FAQ's on our website
www.gsm-activate.co.uk

Alternatively email our technical support team at technical@gsm-activate.co.uk and we will do our best to reply within 24 hours Monday - Friday.