



GSM 2G/3G
SMART SWITCH MINI
e CO RANGE



Product Information

Our 2G/3G GSM Smart Switch is designed to attach to your electronic devices enabling you to activate them using your mobile phone from anywhere in the world.

This can prove to be very useful in a variety of situations. Just simply dial the unit which comes with a free simcard and it will turn the device on or off. Alternatively, you can text it how long you would like the device on for ranging from 1 - 999 seconds or minutes. Once you have sent a command, the device will send an acknowledgement back by text message so you know it has taken your command.

Our GSM 2G/3G Smart Switch is set apart from other models on the market by being on the quadband frequency, this means it can be used worldwide and we frequently ship models all over Europe and worldwide, with excellent feedback.

The unit is also enclosed in a IP65 rated box which means it is perfectly weathered for outside installation and has also passed testing in high temperatures and below freezing conditions.

Specification

- The GSM Switch has been designed to operate electric equipment by using your mobile phone or land line as the controller.
- It is very easy to install and operates with no complicated coding required, just plug in and go.
- GSM Frequency: Quad band freq 850/900/1800/1900/2100 MHz
- Micro 2G or 3G simcard (if 3g purchased)
- Simply dial or text the simcard number to operate the relay.
- If you call the unit it will reject the call so you are not charged.
- You will receive a text acknowledgement to say relay on or off.
- INPUT -(12/24vdc
- 3 AMP N/O Volt free Relay
- Phone list for added security of up to 60 stored numbers.
- You can set the timer for 1 - 999 minutes
- Pulse Function for the relay.
- Sim Active Function.
- Dimensions - L100 X W68 X H50 mm
- Operating Temperature: -10...+40°C
- Relay State Report for relay.
- Text for signal strength.

SIM Active Function

Our GSM Auto Dialler comes with a SIM Active function meaning that it will send a message every six weeks to a preprogrammed number we at GSM Activate own to prevent the SIM card being shut down due to inactivity.

INSTRUCTIONS

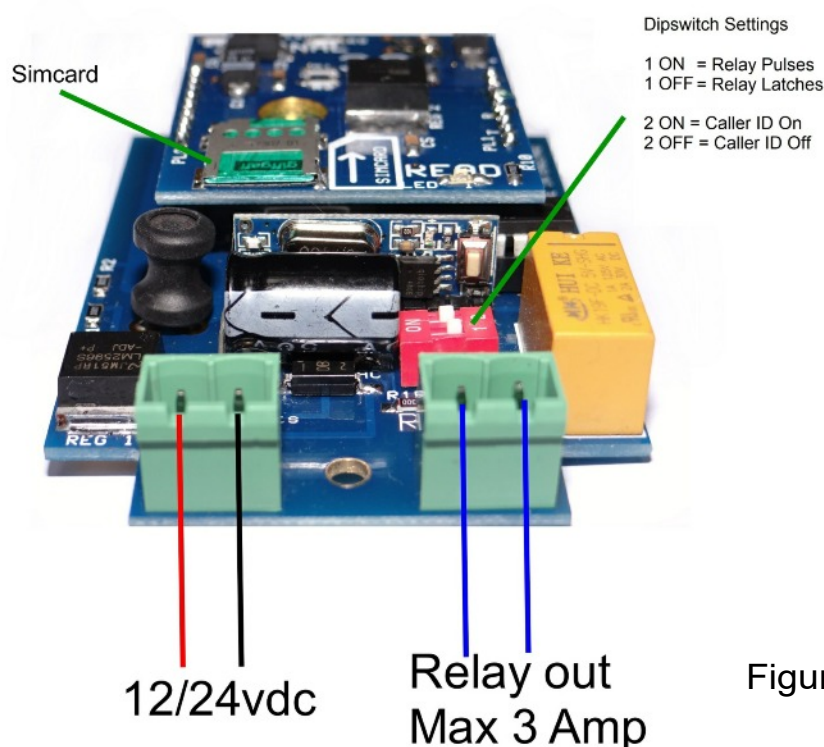

IMPORTANT- PLEASE READ

Please ensure that you disconnect the power when you fit the simcard Then slide the simcard into the holder ensuring the clipped corner of the simcard lines up with the clipped corner of the simcard holder as seen in the image above.

Powering GSM Switch

Connect 12/24 volts to the input connector as per figure 1. Once power has been applied the **blue** network LED light will flash once every second. Once a signal has been found the **green** LED will come on and stay on indicating the unit is now ready for use.

If you have a 3G Smart Switch Mini the unit will automatically connect to the strongest network out of 2G and 3G.

Signal Strength

To check the strength of the signal received please send a text message

#SIGNAL#

The unit will reply back with a score from 1 - 30. The unit must have a score of at least 10 to work effectively. Anything less than a score of 10 will make the unit unreliable.

IMPORTANT - PLEASE READ

We strongly recommend checking the signal strength. The signal strength should at least have a score of 10 for reliability.

How to Programme the GSM Smart Switch Mini

Once the unit has a **GREEN** light, it is ready to be used. The unit can be set by switching dipswitch 2 to the ON position so only authorised numbers you store can activate the unit. If dipswitch 2 is left OFF, anyone phoning the unit number can operate the relay.

IMPORTANT - PLEASE READ - If you do not require authorised users, please skip to the next page.

How to use the GSM Smart Switch Mini

To programme a number to the caller ID (WHL) list you will need to send the text message code:

#WHL#NUMBER#

To delete the number send the text message code:

#DEL#NUMBER#

Example **#WHL#07123456789#** Stores your mobile number (maximum 60 users)

#DEL#07123456789# Deletes the stored mobile number

If the code is accepted the unit will reply "WHL number stored" or "WHL number deleted"

Once the numbers have been programmed please set dipswitch 2 to the ON position.

IMPORTANT - PLEASE READ

You can only send one text message at a time. Please wait for the unit to respond with the text acknowledgement "WHL number stored" before you try to add another number to the system.

Furthermore, please ensure that you have credit on the simcard to receive the text acknowledgements. It may take some time to receive the text acknowledgement depending upon how busy the network is at the time.

Reset Function

For a quick reset and to clear all the numbers stored, there is a built in reset function that can be triggered by sending the text message

#RESET#

The unit will remove all WHL numbers stored.

NOTE - Please only use this function if completely necessary as it will wipe ALL of your numbers.

How to use the Eco Smart Switch Mini

Operate Relay by Call

- 1, Using your mobile phone dial the simcard number within the unit. You will hear 1 ring tone. The unit will automatically hang up therefore, avoiding any call charges.
- 2, The relay will then turn ON and remain on. You will receive a status report reading "REL ON".
- 3, To turn the relay OFF just ring the simcard number again. You will receive the status report "REL OFF".

You can turn the status replies on or off to save credit by sending the text message

#STATE=ON# Turns ON the relay state report

#STATE=OFF# Turns OFF the relay state report

The default setting is for the relay state report is ON

Pulse Relay by Call

If you set DipSwitch 1 to on, the unit will now pulse the relay for 10 seconds instead of latching on. The unit will reply Relay Pulsed once the pulse period has ended

Operate Relay by Text

By texting the unit you can turn ON / OFF the relay. Below are examples on how to do this.

#REL=ON# This will turn ON relay

#REL=OFF# This will turn OFF relay

It is possible to pulse the relay for a period of 10 seconds. You will need to send the text command as follows

#PULSE=REL# This will turn ON the relay for 10 seconds ONLY

Timer Mode - Relay Timer

It is possible to turn the relay ON for a period of time reanging from 1 minute to a maximum of 999 minutes. You will need to send the text message as follows.

#MIN= Followed by the number of minutes you require followed by #

#MIN=060# Turns the relay on for 60 minutes

#MIN=120# Turns the relay on for 120 minutes

The maximum amount of minutes is 999

You will receive the text acknowledgement "TIMER SET".

The timer will stay on for the preset amount of time and then turn itself off. If you wish to cancel the preset time prior to it ending you can send the text

#MIN=000

This cancels the previous set timer.

Operate Relay by Keyfob

You can by a keyfob which works with the unit, Pressing A on the keyfob will replicate what a phone call does ie it will latch or pulse dependant on dipswitch setting

The unit will not reply to a key fob activation

Relay Memory

In the event of a power loss the switch can remember the relay positions for when power has been restored. Please send the text command

#RELMEM=ON# The unit will remember relay status in the event of power failure
#RELMEM=OFF# The unit will NOT remember relay status of the relay.

The default setting is Relay Memory OFF

Relay State Report

It is possible to obtain a relay state report at any time. This will give you the position of the relay. To do this you will need to send a text.

#REL=STATE#

IMPORTANT - PLEASE READ:

The unit has a "sim active" function which monitors the activity on the simcard. If it has been inactive for 6 weeks, it will send an automatic text to a pre-recorded number. This will then eliminate the problem of your sim getting shut down if they are unused for 3 months.

New SIM cards will need registering before they can be used. Full details of how this is done can normally be found in the SIM card pack. It will normally require that the SIM card is inserted into a mobile phone, a number dialled and instructions followed. While the SIM is in the mobile phone it would be a good time to disable any PIN codes, call diverts, ring back and disable features such as voicemail and text alerts. Details of how to do this can be found on the SIM card provider's web site or by calling their customer services. Please use one of the following SIM card providers - Vodafone, TMobile, O2 or Orange.

Please Note - Currently not suitable with the network provider "three"

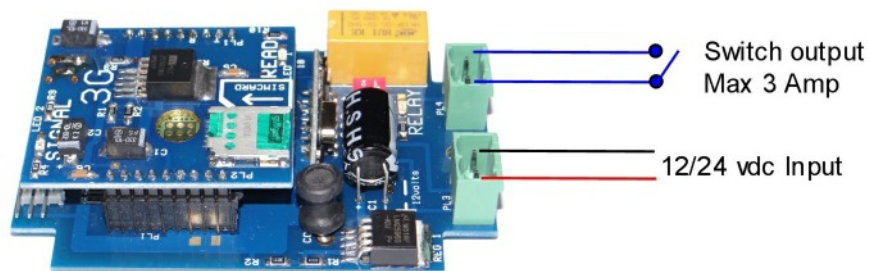

The relay 3 Amp contact volt free

SEND TEXT	OPERATION	ACKNOWLEDGMENT
#REL=ON#	Turns Relay ON	Status Report
#REL=OFF#	Turns Relay OFF	Status Report
#PULSE=REL#	Pulses Relay	Relay Pulse
#REL=STATE#	Gives Relay State Report	Status Report
#MIN=000#	Turns Relay ON (1-999 minutes)	Timer Set/Timer End
#WHL#NUMBER#	Stores Number to White List	Number Stored
#DEL#NUMBER#	Deletes Number from White List	Number Deleted
#RELMEM=ON#	Turns Relay Memory ON	Memory ON
#RELMEM=OFF#	Turns Relay Memory OFF	Memory OFF
#STATE=ON#	Turns Relay State Report ON	Relay State (default on)
#STATE=OFF#	Turns Relay State Report OFF	Relay State
#RESET#	Clears All Numbers from White List	
#SIGNAL#	Gives Signal Strength Test	Score of 1-30

For more technical support please browse the FAQ's on our website www.gsm-activate.co.uk
Alternatively email our technical support team at technical@gsm-activate.co.uk and we will
do our best to reply within 24 hours Monday - Friday.