



2G & 3G GSM Auto Dialler

www.gsm-activate.co.uk



Model number 2G / 3G - AD4IN1V4

Product Information

Our AD-SD Auto Dialler is a versatile unit which can be attached to many of your electronic devices in your homes; work, gardens or wherever you may need it. It will alert you using GSM technology by sending you a text message or phone call to your mobile phone or land line. Therefore alerting you immediately to a problem, failure or status change wherever you are in the world!

Our AD-SD-W WIRELESS version has wireless capabilities to make it a standalone alarm using various wireless sensors.

Our Auto-Dialler is set apart from other models on the market by being on the quad band frequency meaning it can be used worldwide and we frequently ship models all over Europe, USA and Australia with excellent feedback.

The unit is also enclosed in a IP65 rated box which means it is perfectly weathered for outside installation and has passed testing in high temperature and below freezing conditions.

Specification

- GSM Frequency: Quad band freq 850/900/1800/1900/ 3g only model 2100 Mhz.
- Power Supply Voltage: 9 - 24 volts DC - 1 Amp Max
- Current used in standby mode: 60mA Max
- IP 65 Enclosure rating for outside installation
- 4 Inputs Neg triggered
- 1 Inputs poss triggered
- 5 User Numbers
- 8 Amp Relay Output
- Micro Simcard
- No land line required
- Dimensions - L150 x W90 x H45mm
- Dimensions PCB Only - L125 x W67mm
- Sim Active Function
- Operating Temperature: -10...+40°C
- Programmed by Text / SMS Message
- Text to test signal strength

2G OR 3G Model

INSTRUCTIONS

fig 1
TRIGGER LINK
Input 4 only

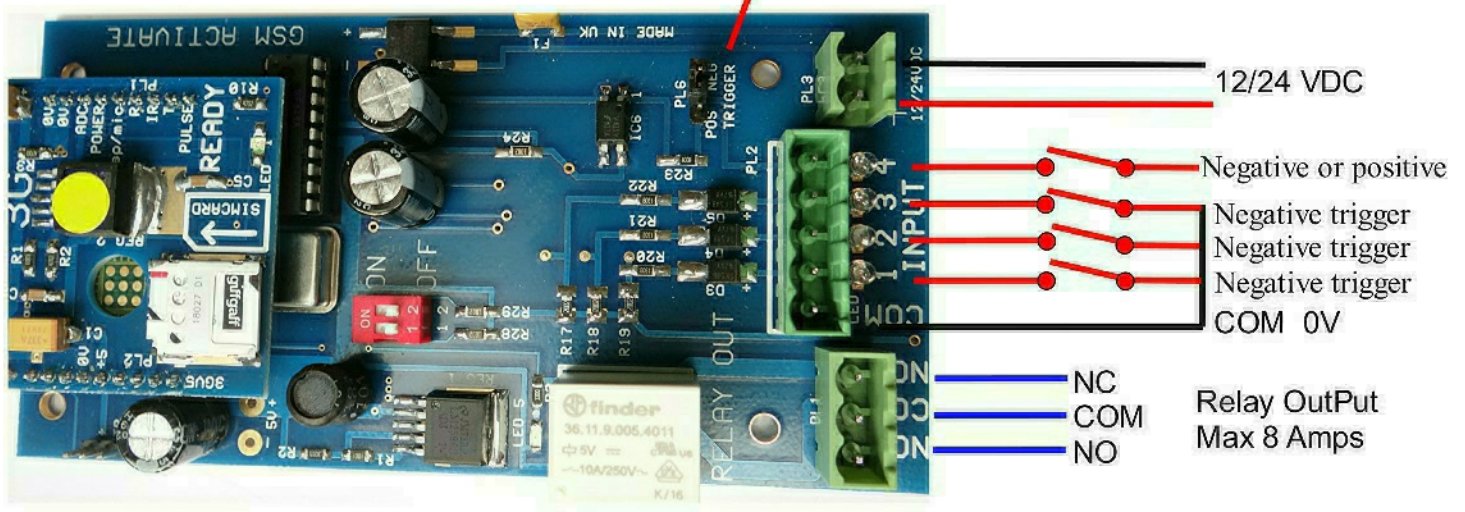

Input 4 only can be negative or positive triggered (fig 1)

Inputs 1,2,3 are all negative triggered

Slide the simcard into the holder making sure that the clipped corner of the simcard lines up with the clipped corner of the simcard holder as picture above.

IMPORTANT - PLEASE READ
PLEASE MAKE SURE YOU DISCONNECT THE POWER WHEN YOU FIT THE SIM CARD THEN PLACE THE SIM CARD WITH THE CLIPPED CORNER FACING IN WARDS. PLEASE SEE PICTURE ABOVE.

SIGNAL STRENGTH:

To help make sure that you place the unit in a suitable position you can text the unit to see how much signal strength the dialler is receiving by texting the command **#SIGNAL#**

The dialler will perform a test on the signal strength.

You will receive a text telling you a signal strength score between 0 up to 30 we strongly recommend that you place the unit where you can receive a signal strength score of at least 10. You will find that with a score of less than 10 the unit will be unreliable.

How to programme contact numbers

After inserting your simcard into the Auto-Dialer turn the unit on and wait until you see the **GREEN READY** LED is on. This will indicate that you have a mobile signal and the unit is ready for use.

You will now need to send a text with the contact number (**maximum 5 contact numbers**)

To avoid confusion we have colour coded the hash (#) and the equals (=) symbols.

Example: (hash) (1 ,2 ,3, 4 or 5) (equals) (phone number) (hash)

#1=07123456789# then send this as a text to the simcard number of your unit

#2=07123562349# then send this as a text to the simcard number of your unit

#5=07136656566# then send this as a text to the simcard number of your unit

If you wish to cancel a number follow this example

Example: (hash) (1 ,2 ,3, 4 or 5) (equals) (DELETE) (hash)

#1=DELETE# Then send this as a text to the simcard number of your unit

NOTE:

Please send one message at a time and wait for the Auto Dialler to send you back the text Acknowledgement 'NUMBER STORED' before you try to add another number.

Below is a notepad to help you remember the numbers that you have saved to your unit in the event you need to modify or delete in the future.

#1= _____ #

#2= _____ #

#3= _____ #

#4= _____ #

#5= _____ #

How to program the SMS text message

You can now change the alarm message for inputs 1 & 2 to your own choosing.

To change the message send the text command as follows.

#MESS1=YOUR MESSAGE# The default message is - **input 1 activated**

#MESS2=YOUR MESSAGE# The default message is - **input 2 activated**

#MESS3=YOUR MESSAGE# The default message is - **input 3 activated**

#MESS4=YOUR MESSAGE# The default message is - **input 4 activated**

This will change the message to "Your Message"

Note:

You can only use a maximum of 19 characters including spaces for your customised message

Telephone call alerts

The auto dialler can be programmed to send you a telephone call after each text alarm has been sent.

You will receive approximately three ring tones. The unit will then hang up automatically. This is to prevent call charges being incurred.

To set call alerts to ON please send the text message

#CALL=ON#

The unit will reply back "call on"

To disarm call alerts please send the text message.

#CALL=OFF#

If the call function has been set to ON you will receive a text message and shortly after a phone call.

How to Use the GSM Auto Dialler

The Auto Dialler has four independent input's

Input 1 = Terminal 1 connection. (Negatively triggered) pulled to ground

Input 2 = Terminal 2 connection. (Negatively triggered) pulled to ground

Input 3 = Terminal 3 connection. (Negatively triggered) pulled to ground

Input 4 = Terminal 4 connection. (Negatively triggered) pulled to ground or

If you require a positive trigger you can use input 4 , if you have set the link to pos (please see page 3 diagram - fig 1)

When the inputs are triggered the **green led** will flash 6 times to indicate that a trigger has been received and it will send a text / call message to the saved user numbers.

- All inputs can be triggered independently.
- The Auto dialler will reset automatically when the triggered input is released.

Alarm Input - Input 4 only

Input 4 can also be used as the alarm input , where the input is not always live and it doesnt auto reset like inputs 1 - 3 , the alarm is only made live by sending a sms text message command, this is useful for attaching things like PIR or Beam Sensors, when you may only want them armed at night.

To activate this mode, send the sms command

#Mode=2# this sets the unit to alarm mode

Once in alarm mode the dialler can only be triggered after you have activated the alarm input by sending the text command as follows.

#ALARM=ON# - You will receive a text message reading **ALARM ON**

With the alarm ON the input 4 will then be live and looking for a trigger, to turn off send the text command

#ALARM=OFF# - This will deactivate the alarm.

The input will not reset automatically after a trigger, you will need to send test message command **#ALARM=ON#** when you want it armed again

To change back to auto mode, send the sms command

#Mode=1# this sets the unit to auto mode (also the default setting)

For 4 Optional wireless inputs, please get in touch with sales on 01273 462380

How to Use the Relay Output

(Dipswitch 2= off) ref page 3

The Auto Dialler has a 8 amp volt free contact relay output which can be used to switch on external electric devices such as lighting, sirens etc.

By texting the unit you can turn the relay ON or OFF. Below are examples on how to do this.

#REL=ON# - This will turn on relay output

#REL=OFF# -This will turn off relay output

After each operation the unit will reply with a status report **RELAY ON/OFF**

It is possible to pulse the output relay for a period of 20 seconds. You will need to send a text as follows.

#PULSE=REL# - This will Pulse the relay for 20 seconds.

(Dipswitch 2= ON) ref page 3

The relay can also be setup to pulse for 20 seconds when the inputs have been triggered. To activate this mode you need to set **dipswitch 2** to the **ON** position. Ref page 3

This can be used to reset auxiliary equipment.

#RESET#

To reset the unit back to factory settings you will need to send a text message **#RESET#**

Warning this will reset all of your parameters, only send a reset command when necessary.

The green ready led will flash 8x

Quick Reference

Send Text	Operation	Acknowledgment
#MESS1=MAX19CHARACTER#	Stores a custom message for input 1	Message 1 Stored
#MESS2=MAX19CHARACTER#	Stores a custom message for input 2	Message 2 Stored
#MESS3=MAX19CHARACTER#	Stores a custom message for input 3	Message 3 Stored
#MESS4=MAX19CHARACTER#	Stores a custom message for input 4	Message 4 Stored
#SIGNAL#	Gives a Signal Strength Test	Score of 1-30
#1=NUMBER#	Saves Contact Number 1	Number Stored
#2=NUMBER#	Saves Contact Number 2	Number Stored
#3=NUMBER#	Saves Contact Number 3	Number Stored
#1=DELETE#	Deletes Contact Number 1	Number Deleted
#2=DELETE#	Deletes Contact Number 2	Number Deleted
#3=DELETE#	Deletes Contact Number 3	Number Deleted
#MODE1#	Sets mode as Auto Mode	Mode 1 On (default)
#MODE2#	Sets mode as Alarm Mode	Mode 2 On (default)
#ALARM=ON#	Sets Alarm to On	Alarm On
#ALARM=OFF#	Sets Alarm to Off	Alarm Off (default)
#STATUS#	Ask for Status Report (Inputs/Relay/Signal)	Status Report
#REL=ON#	Turns On Relay Output	Relay On
#REL=OFF#	Turns Off Relay Output	Relay Off
#PULSE=REL#	Pulses Relay Output for 20 Seconds	Relay Pulse
#CALL=ON#	Switches Text & Call Alerts on	Call on
#CALL=OFF#	Text Alerts Only	Call off (default)

Modular Plug In Boards

The GSM Auto Dialler now has some modular plug in boards which can add extra functionality to our base units. To discuss the new modular boards please call us on 01273 462 380 or email sales@gsm-activate.co.uk. PLEASE IGNORE THIS PAGE IF NOT USING A PLUG IN BOARD

Wireless Add On Plug

Our wireless plug in allows upto 4 sensors to be paired to the dialler , these sensors need to be 433 mhz and 1527 coding . With the wireless plug in, it will turn the auto dialler into a wireless alarm system - the sensors will have a range of 100 metres to the dialler board

Pairing the Sensors

To pair a sensor to the board , you will need to press the pairing button equal to the position you wish the sensor to pair to, and then trigger the sensor ,for example

Press the pairing button once and triggering the sensor will pair the sensor to input 1

Press the pairing button four times and triggering the sensor will pair the sensor to input 4

Led 2 will flash when you press the pairing button, Led 1 will flash when a paired sensor is active.

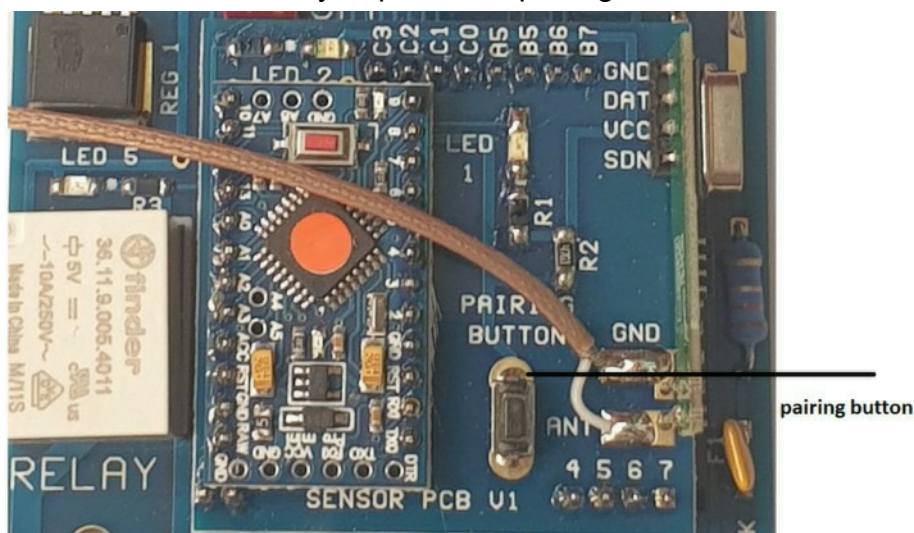

Wired Auto Dialler Inputs and alarm mode

Please note the wired auto dialler inputs will still work, and these will be shared with the wireless sensors, for example if you have the bell of an alarm wired into input 1, and also have paired a beam to input 1 , when either trigger it will send the input 1 text message -so it is best to use seperate inputs for sensors and wired if you require different messages for them.

***Note input 4 cannot be positive triggered when using a modular plug in**

Alarm Mode

The sensors will fall in line with alarm mode settings (page 6)

The only difference is that in Mode 2 Alarm Mode , ALL SENSORS will need to be manually re-armed following a trigger not just input 4.

8 Input Plug high and low trigger Input Board

We now have a plug in board which provides another 4 inputs, and the inputs can be triggered both high and low so you get two inputs per message. As this is a significant difference to the main board, we have a whole new manual which you can request by contacting us.

NOTE -

Please make sure you supply a 9 - 24 volts DC from the battery terminals via a 2 amp fuse (for alarm panel installations)

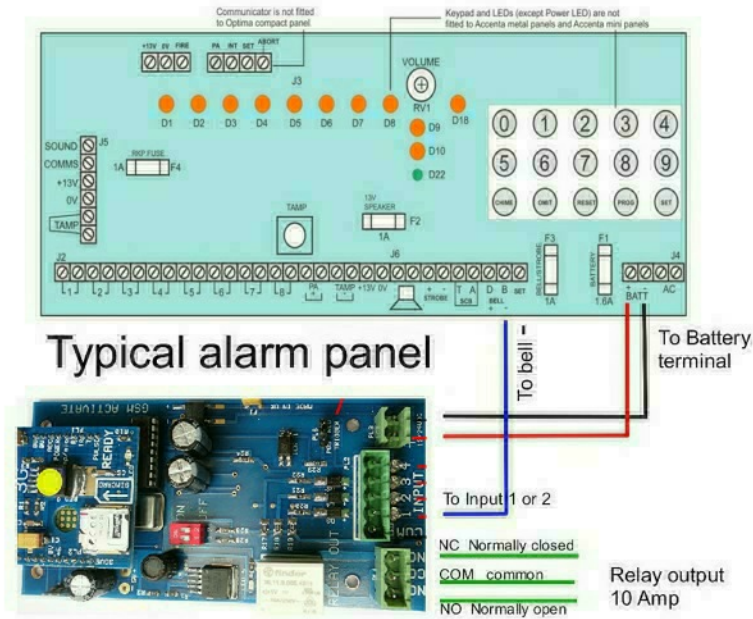

Input 4
Auto or Alarm mode vis sms command
Negative or Positive trigger via link setting

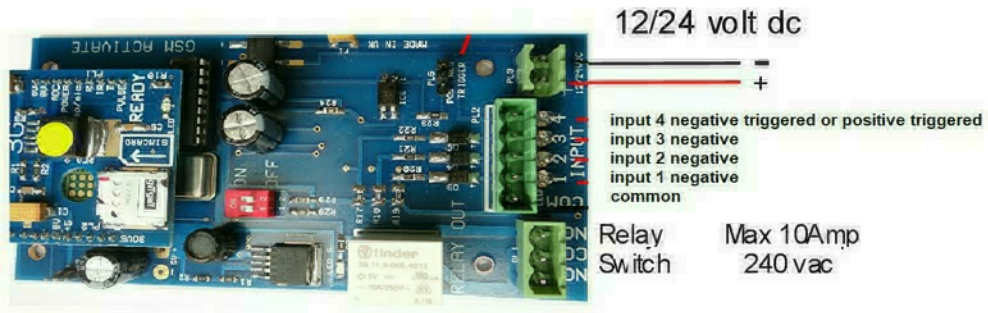

INPUTS

As you can see in the circuit diagram above the inputs can be activated by pulling the input 1,2 & 3 to ground. Alternatively input 4 can be set triggered by pulling to ground, or if the link is applied via a positive trigger

Relay Output Volt free contact

The relay has Common, Normally Open and Normally Closed contacts which are capable of 8 Amp loads. This is suitable for turning ON or OFF electrical equipment. Alternatively it can be used for resetting your alarm system.

The relay can be manually activated by text message commands or it can be set to pulse for 20 seconds when an input has been activated - refer to page 6

For more technical support please browse the FAQ's on our website www.gsm-activate.co.uk Alternatively email our technical support team at technical@gsm-activate.co.uk and we will do our best to reply within 24 hours Monday - Friday.